



www.worksafetech.com

Furniture Brackets for Partition Walls

PB 21.68, PB 21.75, PB 22.00, PB 22.25
PB 31.68, PB 31.75, PB 32.00, PB 32.25
PB 21.68F, PB 21.75F, PB 22.00F, PB 22.25F
PB 31.68F, PB 31.75F, PB 32.00F, PB 32.25F

PRODUCT FEATURES

- Secures items to partition walls without drilling or anchoring to wall or floor
- Item is secured with a special semi-rigid brace that hooks over the partition wall
- Adhesive mounted fastening bracket attaches to top of item
- Single or double bracket configurations for individual or back-to-back cabinets
- Available in black, dark gray, light gray or custom powder coated to match color schemes

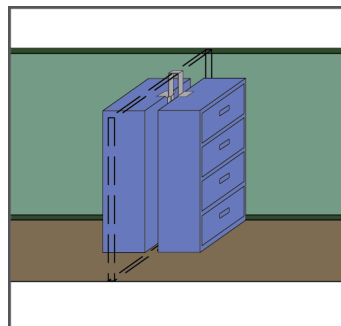
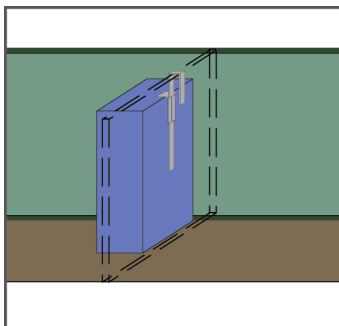
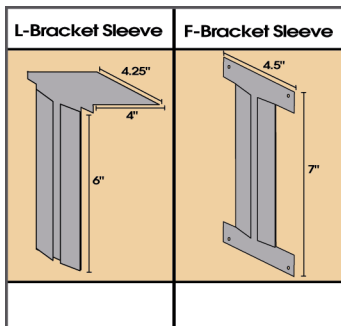
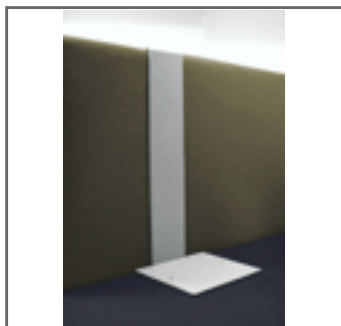
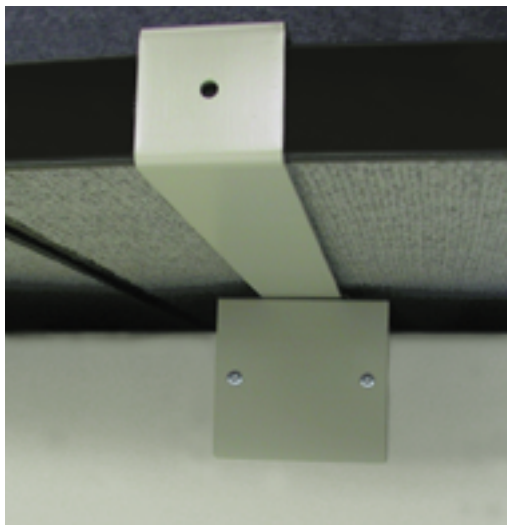

Single Bracket Partition Kit

Back-to-back Partition Kit

The Inside Dimension of bracket is equal to the Outside Dimension of the partition wall.

This partition bracket system is designed to allow easy securing of file and storage cabinets in open-plan partitioned office areas. Each individual file cabinet is secured to the partition wall structure with a special semi-rigid brace that hooks over the partition wall. An adhesively mounted fastening bracket with a rear sleeve is attached to the cabinet. To move an item, simply remove the partition strap out of the rear sleeve and re-attach at its new location. These brackets are available in double bracket configurations for back to back cabinets.

Adhesive system provides 1200 lbs. of shear strength. The optional tek screws help ensure the effectiveness of the adhesive bond.

SPECIFICATIONS

Top Sleeve Bracket:	L - Sleeve = 4.25" x 4" x 6" F - Sleeve = 4.5" x 7" 16 gauge steel 3M® VHB™ adhesive on underside
Partition Strap:	□ 2" x 8" x 25" 10 gauge steel □ Inside Dimension (I.D.) □ PB21.68, PB31.68 = 1.68" I.D. □ PB21.75, PB31.75 = 1.75" I.D. □ PB22.00, PB32.00 = 2.00" I.D. □ PB22.25, PB32.25 = 2.25" I.D.
Colors:	□ □ B = Black G = Dark Gray □ □ □ LG = Light Gray