



www.worksafetech.com

# Lab Floor Leveling Foot

**LF 2148S, LF 2248S  
LF 4148S, LF 4248S**

## PRODUCT FEATURES

- *Designed to anchor large equipment to the floor in labs or clean room environments*
- *Stainless steel prevents corrosion problems*
- *Directly anchor item to the floor*
- *Ideal for large centrifuges*

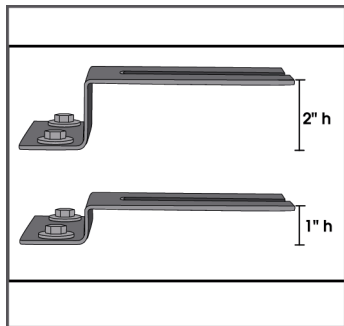
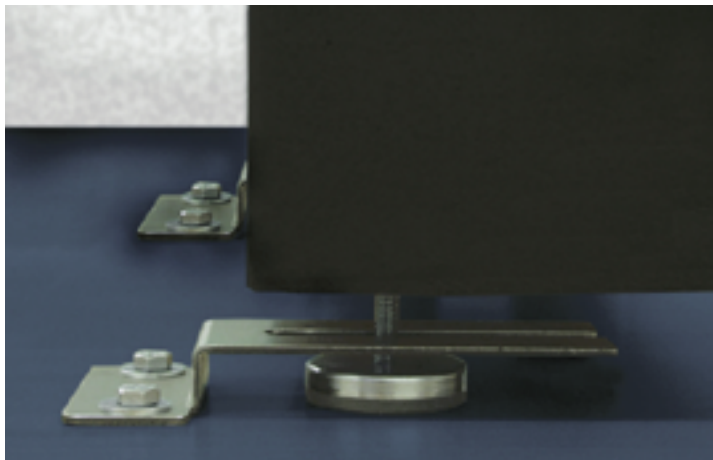

Available in 1" and 2" height

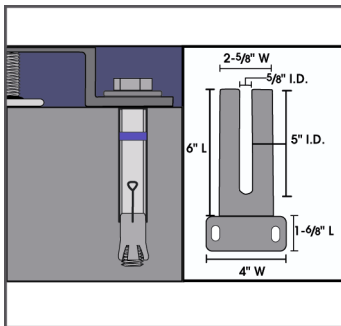

Seismic approved drop-in concrete anchor



Available in two sizes

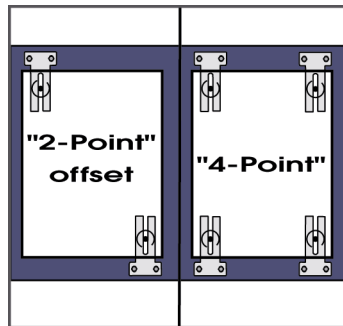

Fastening Methods

This Stainless steel bracket system allows external anchoring of lab equipment to the floor.

The leveling feet capture brackets are corrosion-proof making them ideal for use in laboratories or clean room environments where corrosion is a problem.

## SPECIFICATIONS

**Brackets:** 1/8" Thick Stainless steel with bright finish

- 1" H x 4" W x 8" L - LF 2148S, LF 4148S
- 2" H x 4" W x 8" L - LF 2248S, LF 4248S

**Anchors:** 3/8" Seismic rated drop-in concrete anchors

"2-point" offset fastening kit - LF 2148S, LF 2248S  
"4-point" fastening kit - LF 4148S, LF 4248S