



www.worksafetech.com

Stainless Unibracket™ Wall/Floor Anchoring Kits

**UBFA 223S, UBFK 223S,
UBWK 223S, UBWL 223S**

PRODUCT FEATURES

- *Designed to secure free standing equipment in laboratories or clean room environments to a rear-mount channel*
- *No drilling into item is necessary*
- *Stainless steel prevents corrosion problems*
- *Directly anchor item to the floor or to a Unistrut® channel*

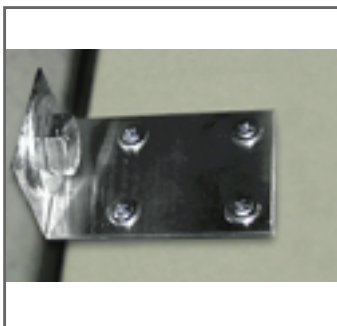

UBWK 223S

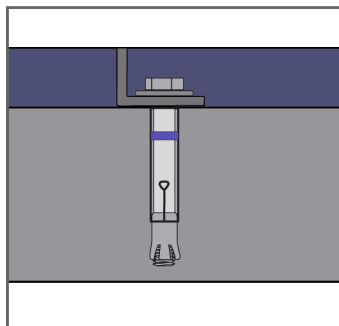

Floor kit comes with seismic rated concrete anchors

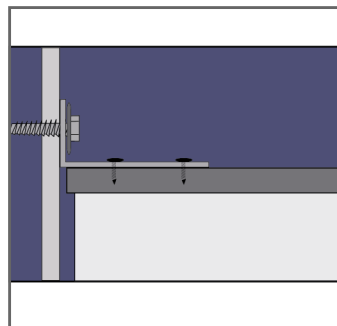

Can be fastened to a wall or floor

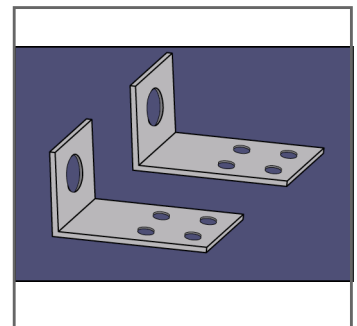

Kits include all hardware

This Stainless heavy gauge steel bracket system allows external fastening of large freestanding laboratory equipment and work tables to the floor. Their low profile design allows them to be placed flush to the cabinet's base without being a tripping hazard.

These brackets are corrosion-proof making them ideal for use in laboratories or clean room environments where corrosion is a problem.

SPECIFICATIONS

- Brackets:** 10 Gauge Stainless steel with bright finish
- 1-7/8" x 9" high with a 2.75" base
 - (10) 3/16" slotted holes
 - (1) 5/8" slotted base hole
 - *accommodates 1/2" drop in anchor

- Anchors:** A = 5/8" seismic rated drop-in concrete anchors
- K = Hilti® Kwik Con™ anchors

Floor Kits: UBFA 223S and UBFK 223S

Wall Kits: UBWK 223S and UBWL 223S