



www.worksafetech.com

# Nitrogen Tank Restraint

TH 21.42S, TH 27.42S

### PRODUCT FEATURES

- Ideal for use inside Lab areas
- All Stainless steel construction
- Anchors to concrete floor
- Restrains tall & short dewars up to 28" in diameter
- Quick release cables for easy access when changing tanks

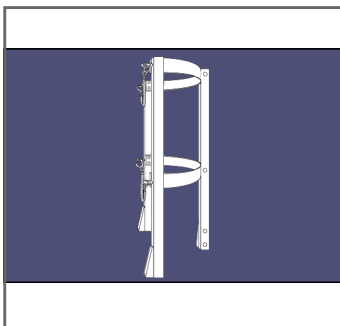
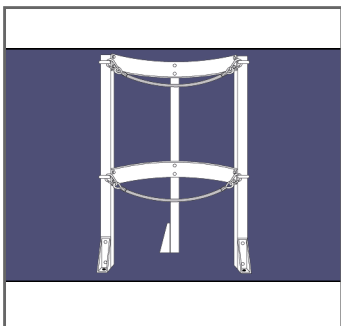
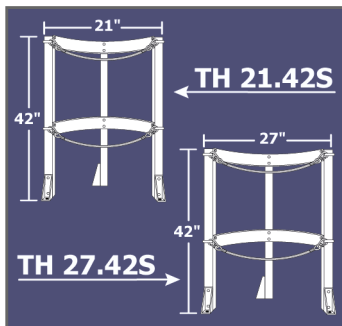

2 cables for OSHA compliance

Unique half circle design

Coated steel cable with Quick Link

These LN2 tank holders are ideal for use inside lab areas because of their all Stainless steel construction.

Tanks can be easily moved in and out of the restraint by removing the cable with the Quick Link end fitting.

The floor area can be easily cleaned since there is no bottom plate.

The half-circle shape uses less floor space than standard storage racks.

Each post is anchored to the floor with Stainless anchors and bolts (provided).

Tank holders can be custom made. Ask your WorkSafe Technologies representative for details.

### SPECIFICATIONS

All Stainless steel construction

TH 21.42S - For LN2 tanks up to 22" in diameter

TH 27.42S - For LN2 tanks up to 28" in diameter